

1ph MINI Standard Control Panel Installation Instructions

Mk 6 Electric Maxidoor

(Link Controller Stock Code 40-5301)

WARNING! Read these instructions **FULLY** before use.
Installation should only be carried out by a **COMPETENT** installer.

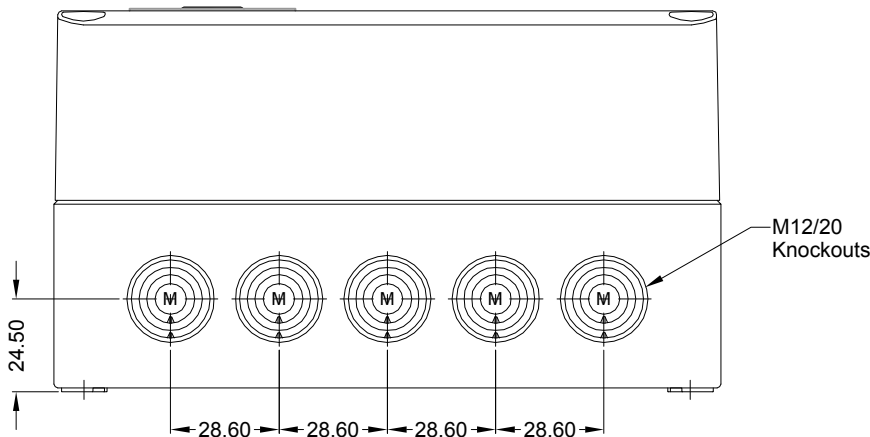
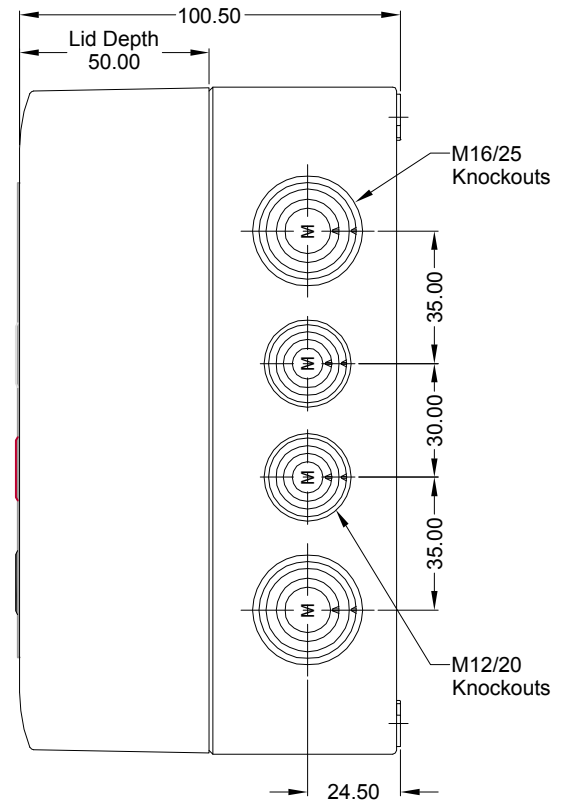
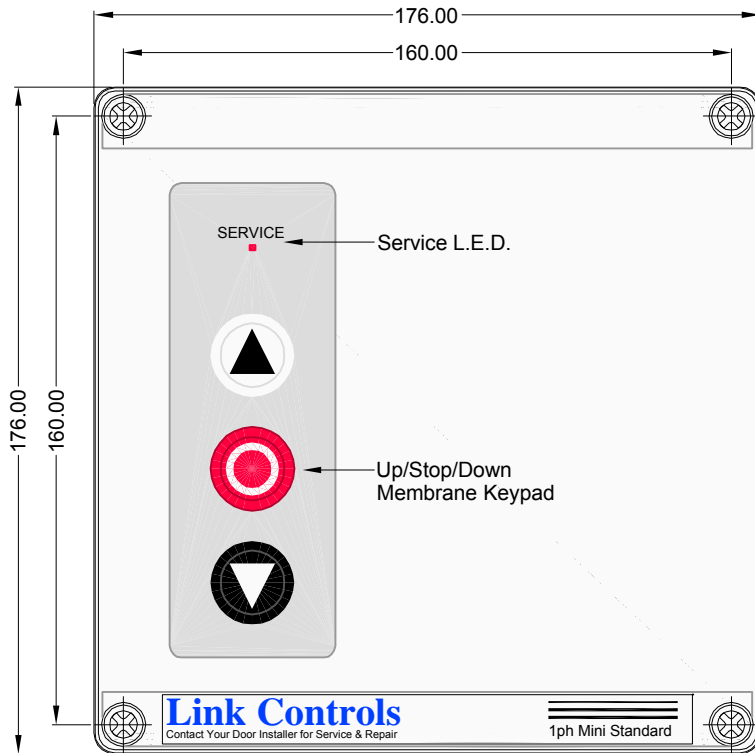

DISCLAIMER: Link Controls Ltd. constantly strives to improve the quality of its goods and as such reserves the right to replace/modify products without prior notification. Any examples given are intended for guidance only.

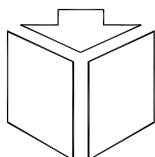

Link Controls Limited

INDUSTRIAL DOOR AND GATE OPERATORS
ACCESS CONTROL & SECURITY EQUIPMENT

STUART ROAD, MANOR PARK, RUNCORN, WA7 1TS
Tel: 01928 579050 Fax: 01928 579259

Drawing No:- LC-1811

Page No:- 1 of 16

Revision No:- K

Rev Date:- 24/11/06

Drawn By:- S.B.P.

Date:- 26/05/00

Checked By:- A.M.

Appr' By:- S.L.

Contents

Enclosure	Page
Specification	01
Installation	
Installation Instructions	03
Maintaining I.P.65 Environmental Protection Rating	03
Installation Procedure	03
Operation	03
Circuit Board	
Control Board Layout	04
D.I.L. Switch Settings	05
Test Buttons	06
Connections	
Power Connections	06
Basic Control Connections	06
Antenna Connections	06
External Auto-Close Connections	06
Terminal Connection Diagram	07
Photocell Connections	08
Safety Edge.....	09
Afterrun/Edge Monitoring Function	09
Optional Plug-in Cards	
Plug-in Loop Detector Card Instructions	10
Installing a Loop.....	11
Plug-in 1/2 Channel Radio Card (RR.1(2)WIP(V)) Instructions	12
Plug-in Traffic Light Controller (Stock Code: 40-5303) Instructions	13
Wiring Examples	
Connection Diagram to a CDO-100 Operator	14
Fault Finding Guide	15
L.E.D. Status	15
Declaration of Incorporation	16

Installation Instructions

1. Knockouts are provided for cable entry, which can be removed as required.
2. For wall mounting, remove the control panel cover via the four fixing screws.
3. Mark up the mounting hole centres at a suitable height & location, which is free from excessive vibration.
4. Drill holes for plugs and Ø4mm fixing screws.
5. Ensure that the control panel is free from debris (swarf, dust, etc.) before wall mounting.
6. Refer to wiring instructions.

Note:-

All connections to the control panel **MUST** be made in accordance with the connection diagram and all terminations **MUST** be securely tightened.

Maintaining I.P.65 Environmental Protection Rating

TO MAINTAIN THE BEST PROTECTION AGAINST WATER / MOISTURE IT IS RECOMMENDED THAT **ALL** OF THE ENTRIES ARE MADE FROM THE BOTTOM OF THE ENCLOSURE.

1. When cabling, ensure that the correct cable gland size is used with an appropriately sized sealing ring.
2. Under **NO** circumstances must an unsecured cable enter the panel through a grommet.
3. The enclosure has been designed to exclude dust, moisture, etc. so therefore it is essential to select the correct cable glands in order to maintain the integrity of the enclosure.

Installation Procedure

1. Manually operate the door into the mid-position.
2. Ensure all D.I.L. switches are OFF.
3. Apply power to the control panel.
4. Press the Open test button, the door will open in Deadman mode (D.I.L. Switch 1 OFF, default).
Note:- Be prepared to stop the door as the direction of travel may be the opposite of expected.
5. Stop the door at the `Fully Open` position.
6. Set the appropriate Open limit cam. (See instructions issued with operator for Limit Setting procedure)
7. Press the Close test button, the door will close in Deadman mode (D.I.L. Switch 2 OFF, default).
8. Stop the door at the `Fully Closed` position.
9. Set the appropriate Close limit cam. (See instructions issued with operator for Limit Setting procedure)

Set D.I.L. switches `1` & `2` to the ON position to enable Impulse operation (i.e. Press & Release).

Caution!

In order to comply with current regulations, Impulse Close operation **MUST** only be used in conjunction with a monitored safety edge system, otherwise Deadman Close operation should be selected (i.e. retain D.I.L. Switch 2 in the OFF position).

Operation

The door may be opened & closed in Deadman mode using either the test pushbuttons during installation or the remote pushbuttons during normal operation with selectable Deadman or Impulse mode (See D.I.L. Switch Settings for further information).

If a safety device is actuated during the closing cycle, then the door will stop for approximately 0.5 seconds before returning to the Fully Open position. Once the obstruction has been removed, the door will attempt to close if either a close signal has been given or after the pre-set time (Default: 15 seconds) if the Automatic Return function has been selected.

Control Board Layout

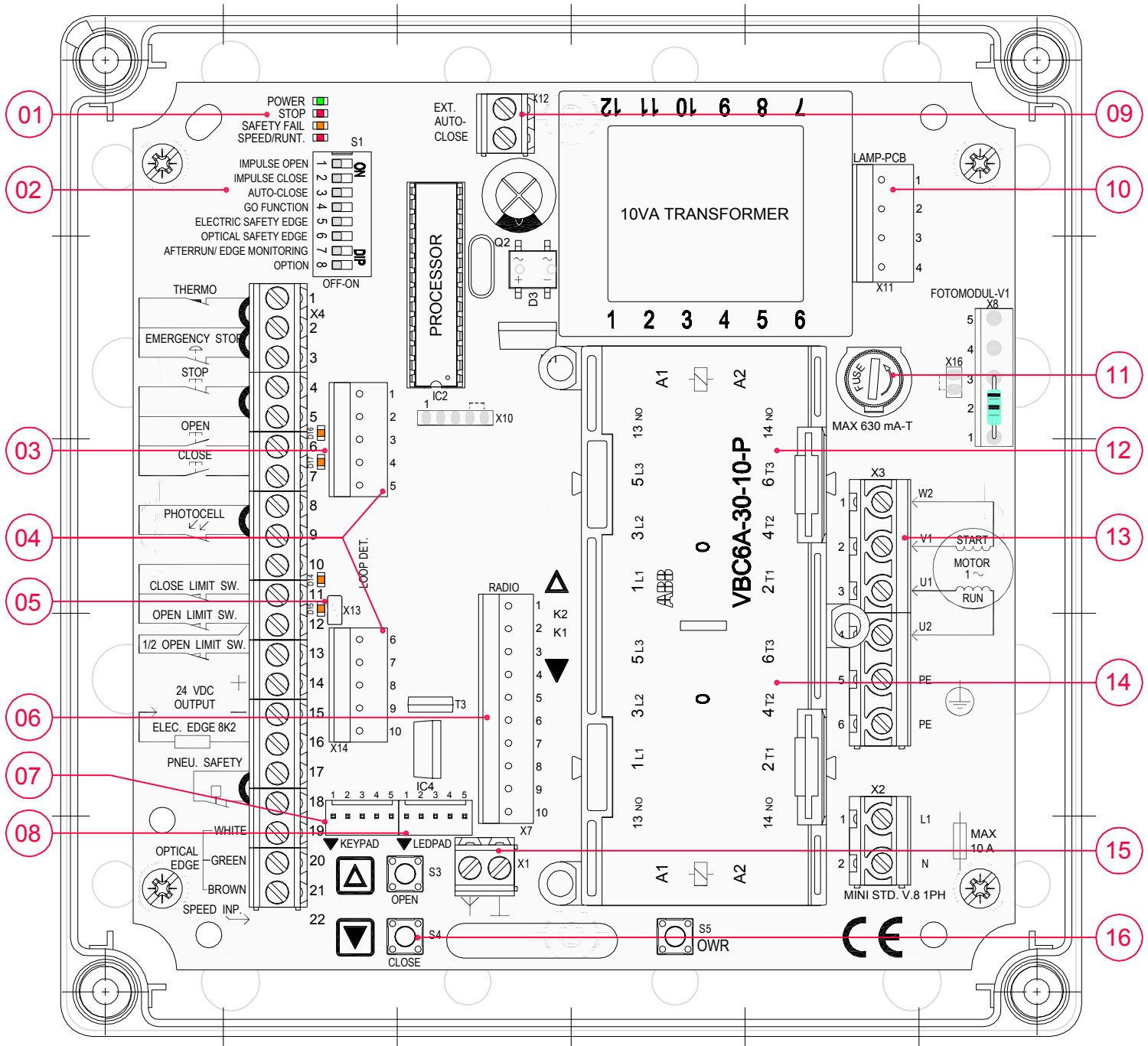

Key	Description	Reference	Key	Description	Reference
01	Circuit board Status L.E.D.'s	Page 15	09	External Auto-Close	Page 06
02	D.I.L. Switches	Page 05	10	Plug-in Traffic Light Controller (Optional)	Page 13
03	Pushbutton L.E.D.'s	Page 15	11	630mA Fuse	-
04	Plug-in Loop Detector Card (Optional)	Page 10	12	Open Contactor	-
05	Limit Switch L.E.D.'s	Page 15	13	Power Terminals	Page 06
06	1/2-Channel Plug-in Radio Card (Optional)	Page 12	14	Close Contactor	-
07	Membrane Keypad Connector	-	15	Antenna Terminals	Page 06
08	Membrane Service L.E.D. Connector	Page 05	16	Test Buttons	Page 06

D.I.L. Switch Settings

1: Impulse Open

When enabled, it activates Impulse Open operation (Press & Release).

2: Impulse Close

When enabled, it activates Impulse Close operation (Press & Release).

3: Variable Auto-Close Timer

Enables the Variable Auto-Close Timer, which is fully adjustable between 1-240 seconds

Setting the Variable Auto-Close

1. Turn D.I.L. Switch 3 to ON & Run the door to the Fully Open position.
2. Press and hold the 'OPEN' & 'CLOSE' pushbuttons together for 5 seconds.
3. The Red, 'STOP' L.E.D. will flash to indicate learning mode.
4. Press the 'CLOSE' pushbutton once the required time has elapsed.
5. The new Auto-close time has been set.

Note:- If the Mini Standard is left in learn mode, the Auto-close time will default to 15s (Factory pre-set).

4: GO Function

When enabled, it activates the 'OPEN' button as a GO Function (Opens a door, Closes a fully open door, Reverses a closing door). Set this D.I.L. Switch to ON if Single Button Radio operation is required.

5: Electric Safety Edge (8K2)

When enabled, it activates the Electric Safety Edge input.

Note:- If the Electric Safety Edge input is enabled, it is prioritised over the Pneumatic Safety Edge input.

6: Optical Safety Edge

When enabled, it activates a FRABA Compatible Safety Edge input.

7: Afterrun/Safety Edge Monitoring

When enabled, it activates the Afterrun function, which uses the Close limit (set 50mm from the floor) as a safety edge override limit. When the Closed limit is activated the operator electronically overruns this limit (max. of 0.3 seconds) until a signal from the safety edge is received. If no safety edge signal is received, the 'Safety Fail' L.E.D. will flash and the door will fail to Deadman Mode. To reset, simply close the door fully until a safety edge signal is received.

8: Service Interval Counter (See also inside lid of MINI Standard enclosure)

When enabled, it allows the 'No. of Operations' service interval to be set. The counter value is entered via D.I.L. Switches:- Sw.1 (1K); Sw.2 (5K); Sw.3 (10K); Sw.4 (20K); Sw.5 (30K); Sw.6 (40K) & Sw.7 (50K).

Note:- Record the original D.I.L. switch settings prior to Service Counter adjustment.

Setting the Service Counter

1. Move ALL D.I.L. switches to the OFF position.
2. Set D.I.L. Switch 8 + only one other D.I.L. switch (1-7) to the ON position to schedule the required service interval, based on "No. of Operations" & indicated via the "Service" & "Speed/RunT." L.E.D.'s.
3. Press and hold the 'OWR', 'OPEN' & 'CLOSE' buttons together for 3 seconds.
4. The Service L.E.D. will illuminate for 3 seconds to confirm that the Service Counter has been set.
5. Return all D.I.L. switches to the previous configuration for normal door operation mode.

Resetting the Service Counter

1. Press and hold the 'OWR', 'OPEN' & 'CLOSE' buttons together for 3 seconds.
2. The Service L.E.D. will illuminate for 3 seconds to confirm that the Service Counter has been reset.

Disabling the Service Counter

1. Move ALL the D.I.L. switches to the 'ON' position.
2. Press and hold the 'OWR', 'OPEN' & 'CLOSE' buttons together for 3 seconds.
3. The Service L.E.D. will light for 10 seconds to confirm that the Service Counter has been disabled.
4. Return all D.I.L. switches to the previous configuration for normal door operation mode.

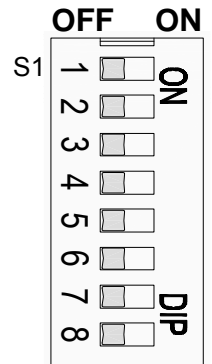

Note:- Move required D.I.L. Sw. right to set to **ON** & enable option

Test Buttons

S3: "OPEN" Test Button

Press to Open the door whilst setting the limits. Ensure door travels in the correct direction.

S4: "CLOSE" Test Button

Press to Close the door whilst setting the limits. Ensure door travels in the correct direction.

S5: "OWR" (Override) Test Button

In case of a failure of the pneumatic edge, photocell or loop these can be overridden by this button. The controller will then change to Deadman Closing. Press, in conjunction with the "CLOSE" Test Button.

Connections

Power Connections

1. 1ph Motor: Connect a suitable motor to terminals `W2`, `V1`, `U1`, `U2` & `PE` as illustrated on page 7.
2. Supply: Connect a 1ph/230V/Neutral/Earth suitably fused (6A Max.) supply to terms. `L1`, `N` & `PE`.

Basic Control Connections

1. Thermal Trip: Connect a N/C contact from the thermal trip to terminals `1` & `2`.
Note:- Alternatively, the thermal trip may be connected in series with the common leg of the Open & Close limit switches - Both options are shown on page 7.
2. Emergency Stop Pushbutton: Connect a N/C contact from the E.Stop pushbutton to terminals `2` & `3`.
3. Stop Pushbutton: Connect a N/C contact from the Stop pushbutton to terminals `4` & `5`.
4. Open Pushbutton: Connect a N/O contact from the Open pushbutton to terminals `5` & `6`.
5. Close Pushbutton: Connect a N/O contact from the Close pushbutton to terminals `5` & `7`.
6. Photocell: Connect a N/C contact from the Photocell to terminals `8` & `9` (See page 8).
Note:- If more than one photocell is to be fitted, they must be connected in series across these terms.
7. Safety Interlock: Connect a N/C contact from the safety interlock between terminal '10' and in series with the common leg of the limit switches.
Note:- Alternatively, if the 2nd wiring option (See #1) is chosen, connect the N/C contact of the safety interlock in series with the thermal trip and the common leg of the Open & Close limit switches.
8. Close Limit: Connect a N/C contact from the Close limit switch to terminals `10` & `11`.
9. Open Limit: Connect a N/C contact from the Open limit switch to terminals `10` & `12`.
10. Part (1/2) Open Limit: Wire a N/C contact from the 1/2 Open limit in parallel with a N/O keyswitch and connect to terminals `12` & `13`.
Note:- This signal is normally "Linked Out" - To activate, remove Jumper 'X13' & operate the keyswitch.
11. 24VDC Output: A 24VDC @ 150mA output is available at terminals `14` & `15` for auxiliary equipment.
Note:- If a radio card is fitted the output will be reduced to 100mA.
12. Electric Safety Edge: Connect the electric safety edge to terminals `15` & `16` (See page 9).
13. Pneumatic Safety Edge: Connect the pneumatic safety edge to terminals `17` & `18` (See page 9).
14. Optical Safety Edge: Connect the 3-wires (White, Green & Brown) from the transmitter and receiver of the FRABA Compatible Optical safety edge in parallel and terminate to terminals `19` (White), '20' (Green) & `21` (Brown) respectively (See page 9).
15. Speed Input: Not Used - Reserved for future expansion.

Note:- Links are provided to bridge certain N/C contacts. Remove these links from any input required.

Antenna Connections

1. Antenna: Connect the Antenna wire to terminal 'Ψ' and the ground to terminal '1' of Terminal Block 'X1'.

External Auto-Close Connections

1. External Auto-Close: Connect a N/O contact from a latching switch (e.g. Keyswitch or Toggle Switch) to the terminals of Terminal Block `X12`.

Note:- D.I.L. Switch 3 **MUST** be set to OFF for this function.

Terminal Connection Diagram

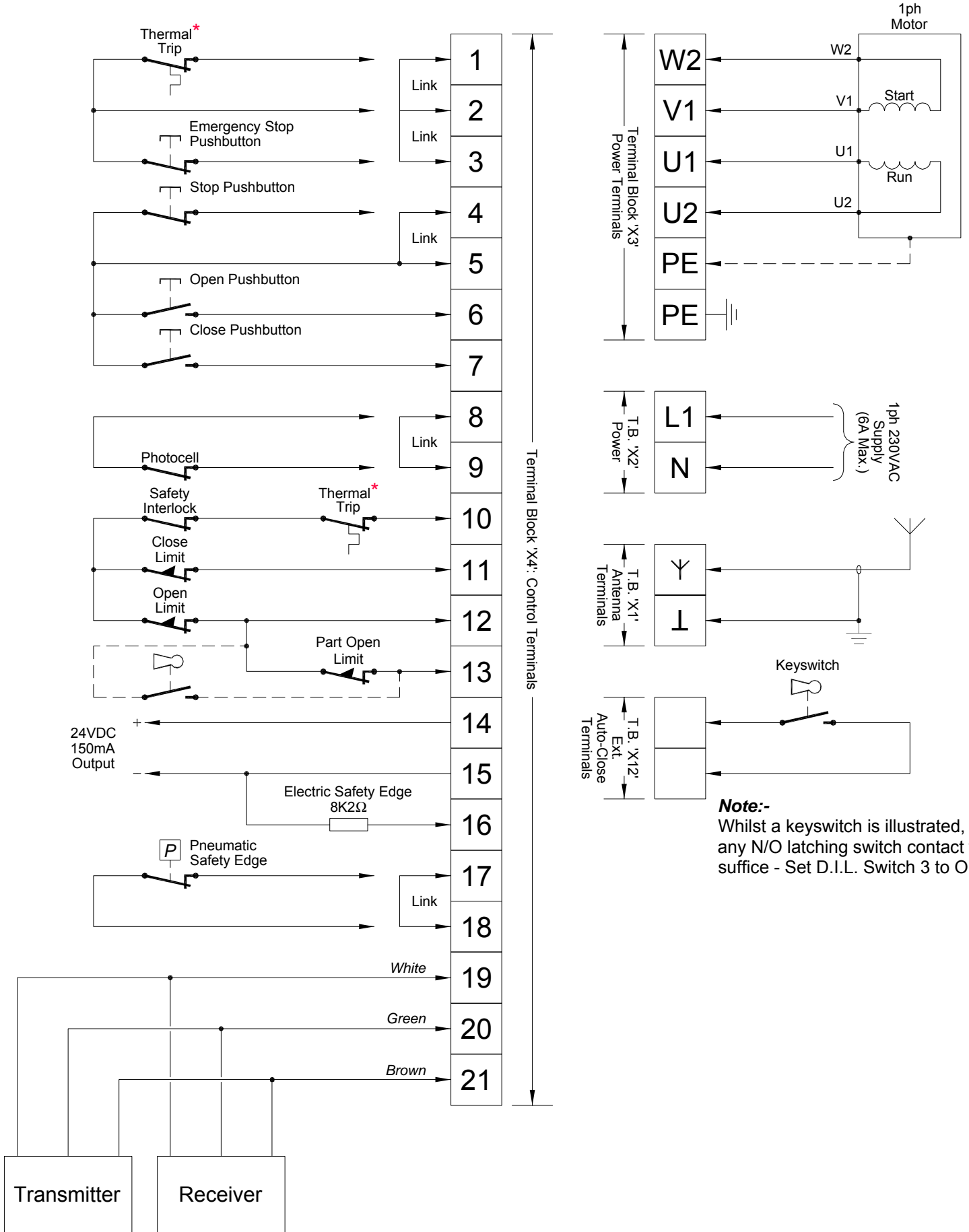

Note:-
 Whilst a keyswitch is illustrated, any N/O latching switch contact will suffice - Set D.I.L. Switch 3 to OFF.

***Note:-**
 The thermal trip contact can be wired in either of the two positions indicated.

Fault Finding Guide

Note:- A test meter, able to test Voltage & Continuity, is required for fault finding.

Fault	Procedure
The door will not operate	Check that the supply is O.K. - is the 'POWER' L.E.D. ON? Check the safety device, stop & limit switch circuits are N/C.
The door will only travel in one direction, regardless of which pushbutton is pressed	Check the safety device, photocell & limit switch circuits are N/C. Check the link is correctly fitted between terminals '8' & '9'.
The door closes when the Open pushbutton is activated & vice versa	Interchange connections 'W2' & 'V1'.
The door stops before the Fully Open or Close limits are actuated	Check that the Open & Close limit stops are set correctly. Check that the thermal trip has not actuated. If the motor has been run continually it will get hot, therefore actuating the thermal trip; allow it to cool before proceeding.
The door closes but will not open or opens but will not close	Check that the open & close limit stops are set correctly. Check that the limit wires in terminals '10', '11' & '12' are correct.

Note:-

N/C - Normally Closed;

N/O - Normally Open

L.E.D. Status

L.E.D.	Tag	Status	Description	Action
GN	POWER	ON	24VDC Supply Healthy	N/A
		OFF	No 24VDC Supply	Check Fuse F1 & Mains Supply
RD	STOP	ON	Stop Circuit(s) Open	Check '1 & 2', '2 & 3' + '4 & 5'
		ON	Open & Close limits made simultaneously	Check Limits & Interlock Circuit
		Constant Flashing	Learning Mode of the Auto-Close Timer Function activated	Press the Close pushbutton once set time has elapsed - See Page 5
		OFF	O.K.	N/A
OG	SAFETY FAIL	ON When Close P.B. is pressed	Safety Devices are open circuit Is D.I.L. Switch 5 ON when no Electric Edge is fitted?	Check '8 & 9', '15 & 16' + '17 & 18' Switch D.I.L. Switch 5 OFF
		Constant Flashing	Safety Edge Monitoring is ON (D.I.L. Switch 6) & No safety edge signal was received when the door is fully closed	Check Safety Edge
		OFF	O.K.	N/A
RD	SPEED /RUNT.	ON	Door has exceeded Run Time	N/A
		Constant Flashing	"No. of Operations" has reached Service Interval	Service Unit & Reset Service Counter - See page 5
		OFF	O.K.	N/A
OG	D14	ON	Close limit switch is open circuit	N/A
		OFF	Close limit switch is closed circuit	N/A
OG	D15	ON	Open limit switch is open circuit	N/A
		OFF	Open limit switch is closed circuit	N/A
OG	D16	ON	Open pushbutton activated	N/A
		OFF	Open pushbutton not activated	N/A
OG	D17	ON	Close pushbutton activated	N/A
		OFF	Close pushbutton not activated	N/A

Key:

GN: Green

RD: Red

OG: Amber

N/A: Not Applicable

Link Controls Ltd.

Registered Office
Stuart Road, Manor Park, Runcorn, WA7 1TS
Tel: +44(0)1928 579050 • Fax: +44(0)1928 579259
Registered in England No. 2525292

Declaration of Incorporation

Product: Motor Controller
Type: 1ph MINI Standard
Version: 8

Declaration is in compliance with:

Machinery Directive 98/37/EC, meeting the Essential Health & Safety Requirements relating to the Design and Construction of Machinery and also the Supply of Machinery (Safety) Regulations, as implemented in the United Kingdom.

Declaration: The equipment supplied by Link Controls Ltd. when installed and maintained according to all the Manufacturer's instructions, in combination with the completed machinery or system that has also been installed and maintained according to all the Manufacturer's instructions, meets the requirements of the Machinery Directive 98/37/EC.

I, the undersigned, hereby declare that the equipment specified above and any accessory listed in the manual conforms to the above Directives and Standards.

Name: Andy Molloy

Signature: 

Position: Technical Director

The machinery to which this Declaration of Incorporation relates must not be put into service until the relevant machinery into which it is to be incorporated has been declared in conformity with the provisions of the Machinery Directive 98/37/EC, as amended, and the national legislation related to its implementation.

Hand Chain Interlock Detail

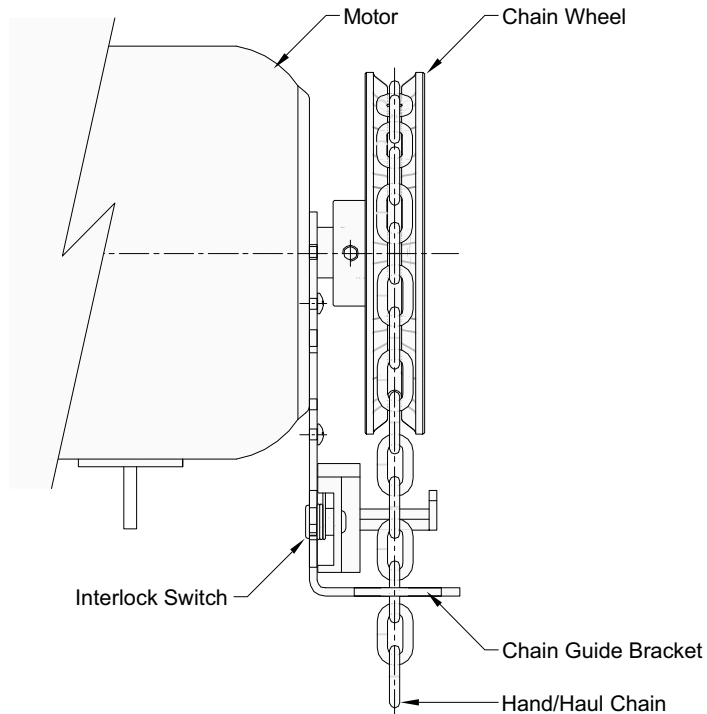

Important: Before engaging hand chain in Point 2, release motor brake by pulling lever back and swivelling washer



Motor brake engaged



Motor brake released

1. Ensure power to the door control is isolated to prevent accidental switch on.
 2. Lift the hand chain off the safety switch and place it on the chain wheel.
 3. The door can now be operated by hand chain.
- Once power is restored, the above procedure should be reversed.
4. In the event of any problem, please contact your installer.

Field Installation & Wiring for a 1ph 5-Wire 0.75kW 'TVRA-8/3' Operator c/w High Level Hand Chain Interlock

WARNING! Read these instructions **FULLY** before use. Installation should only be carried out by a **COMPETENT** installer.

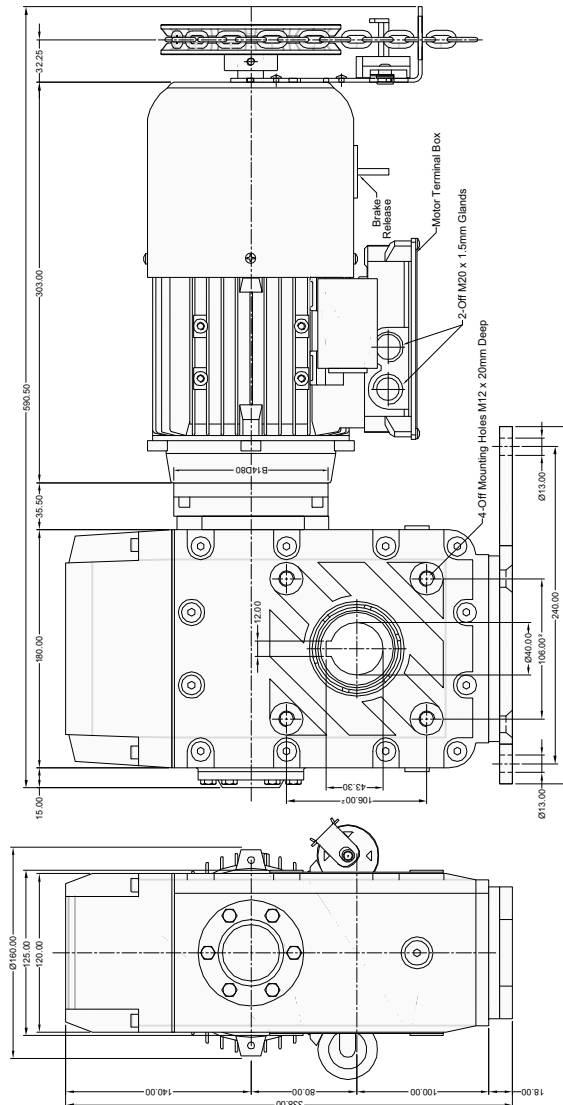

DISCLAIMER: Link Controls Ltd. constantly strives to improve the quality of its goods and as such reserves the right to replace/modify products without prior notification. Any examples given are intended for guidance only.

T: +44 (0)1928 579050
 F: +44 (0)1928 579259
www.linkcontrols.co.uk
sales@linkcontrols.co.uk

Link Controls
Marantec uk

Stuart Rd, Manor Park, Runcorn, Cheshire, WA7 1TS

Drawing No:- LC-1920	Page No:- 1 of 3
Revision No:- B	Rev Date:- 26/02/10
Drawn By:- S.B.P.	Date:- 26/07/00
Checked By:- A.M.	Appr' By:- F.T.

Installation Instructions

1. Mount the operator securely in position using a suitable mounting plate.
2. Manually operate the door & adjust the limit switches so that they correspond to the position (see Fig. 1).
Green Cam = Fully Open
Black Cam = Fully Closed
3. Ensure that the power supply is suitably fused (max. 6 Amps).
 - i. Connect the power supply to the control panel.
 - ii. Connect the power supply, limits and safety circuit from the door operator to the control panel.
 - iii. Manually operate the door to the mid-position and check that the door operates electrically in the correct direction.

WARNING!

After initial installation the operator direction may be wrong so be prepared to press the Stop button, as incorrect rotation may result in damage to the door. To correct the operator direction, interchange two of the incoming supply phases with each other.

Limit Switches

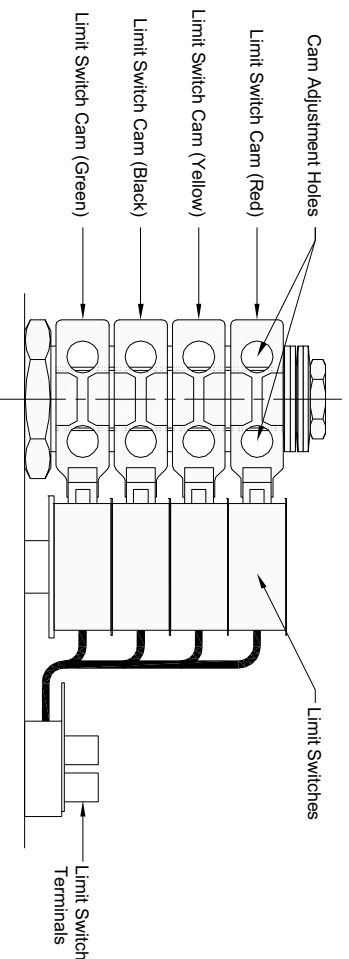

Fig. 1

The limit switches provide a signal to stop the door when it reaches the fully open & fully closed positions. The limit switches must be adjusted and wired to the control panel to ensure that the door stops in the correct position.

Limit Switch Adjustment

Adjustment of the limits can be made by inserting a rod or small screwdriver into one of the cam adjustment holes and rotating the cam around its shaft.

Note:-

Ensure that the green limit switch is set in the required position first, before the black limit switch.

- Green Cam = Open limit
- Black Cam = Close limit
- Yellow Cam = Auxiliary limit
- Red Cam = Auxiliary limit

Connections & Wiring

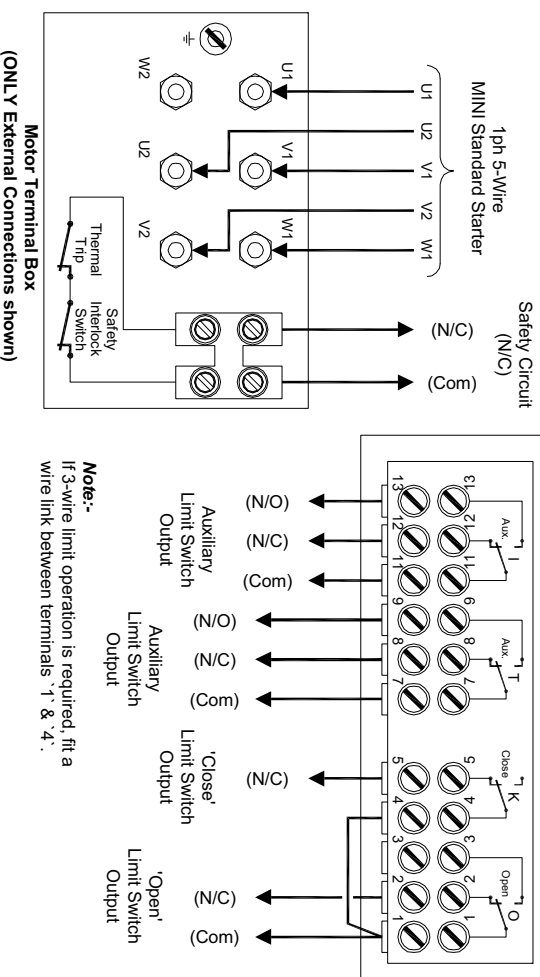

Note:-

Ensure that the thermal trip is connected in series with the safety interlock switch to the control panel safety circuit (as shown in the diagram above).

IMPORTANT!

ONLY a modified 5-wire MINI Standard Starter to be used

T: +44 (0)1928 579050
F: +44 (0)1928 579259

www.linkcontrols.co.uk
sales@linkcontrols.co.uk



Stuart Rd, Manor Park, Runcorn, Cheshire, WA7 1TS

Title:-

FIELD INSTALLATION & WIRING FOR A 1PH 5-WIRE 0.75KW TVRA-8/3 OPERATOR
C/W HIGH LEVEL HAND CHAIN INTERLOCK

Drawing No:- LC-1920 Page No:- 2 of 3

Revision No:- B Rev Date:- 26/02/10

Drawn By:- S.B.P. Date:- 26/07/00

Checked By:- A.M. Appr' By:- F.T.