

VVS[®]

Variable Ventilation System (Cable Drive)



ENG

User Instructions



Ver: 2013/11/ENG

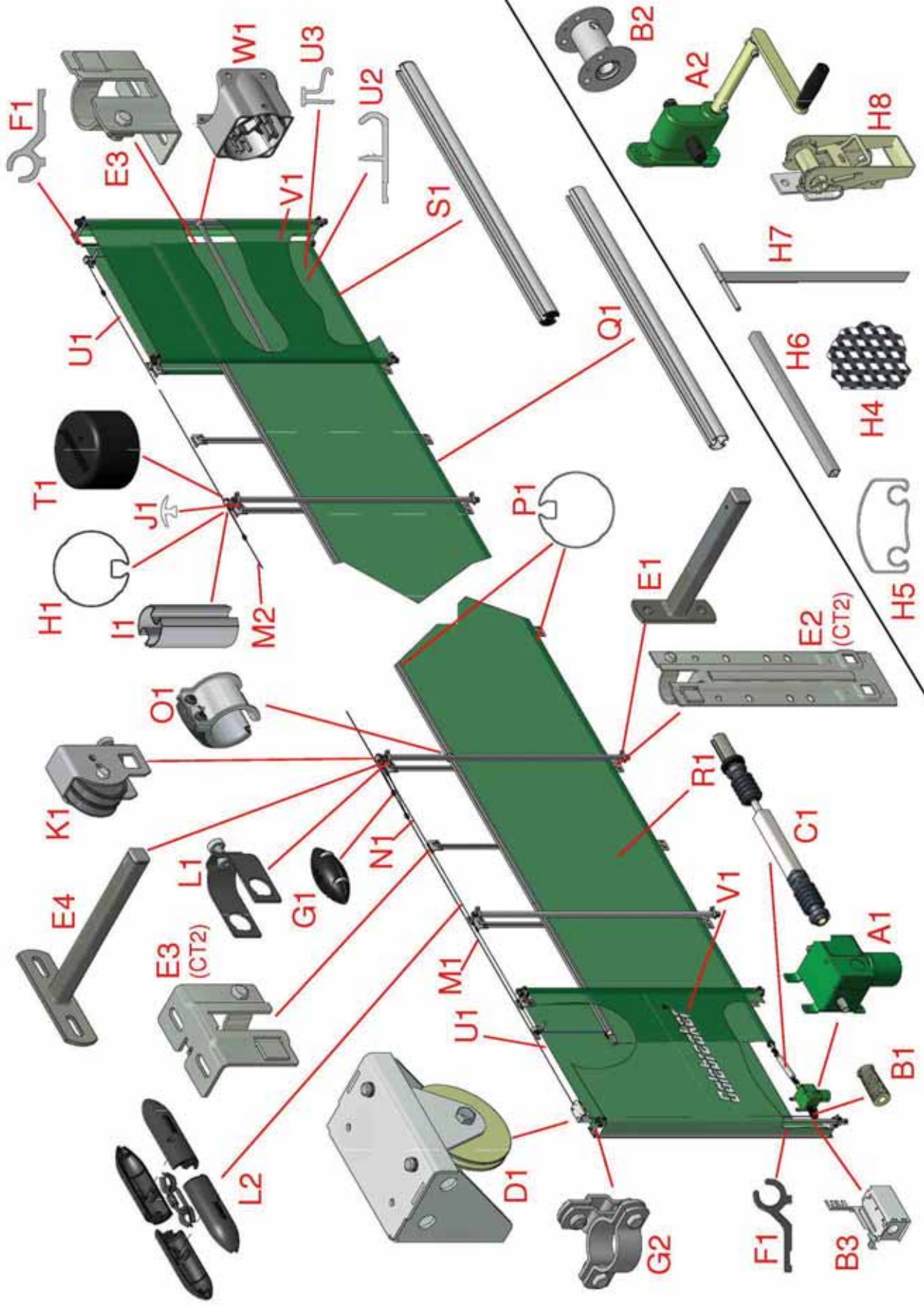

Figure 1a, System Overview (Bottom Rolling)

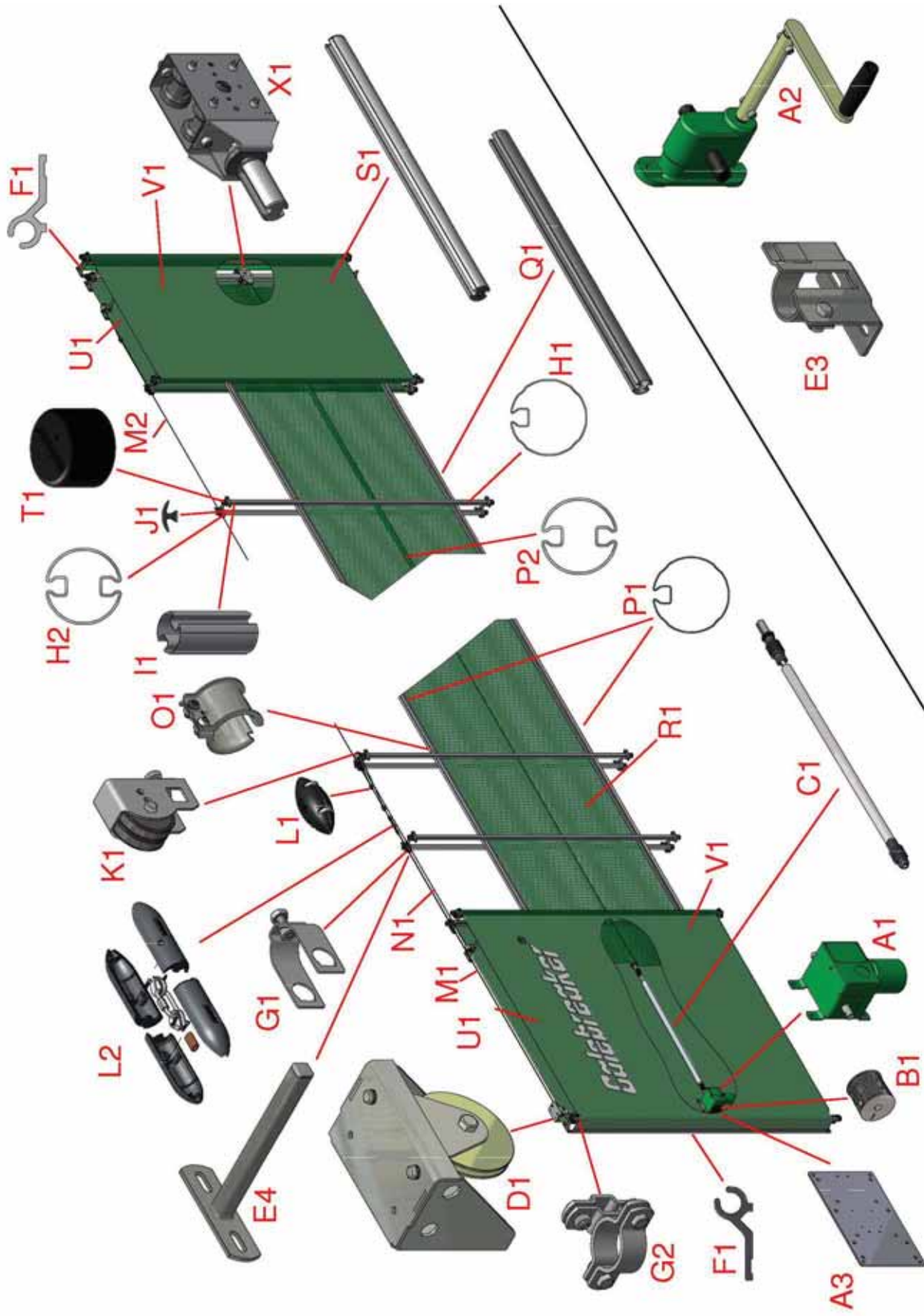

Figure 1b, System Overview (Middle Rolling)

1. Introduction

Parts List

FIGURE 1 REF:	QTY	PRODUCT DESCRIPTION
A1	1	Drive Mechanism (Motor)
A2	1	Drive Mechanism (Manual)
A3	1	Drive Mounting Plate
B1	1	Grooved Cable Drum (Motor drive only)
B2	1	Smooth Cable Drum (Manual drive only)
B3	1	Cable Drum Cover (Motor drive only)
C1	1	Telescopic Shaft
D1	1	Corner Pulley
E1	*	Short Face Bracket with 20mm Square Tube
E2	*	Lower Mounting Face Support for 49mm Tube (CT2)
E3	*	Ground / End Support for 49mm Tube
E4	*	Long Face Bracket with 20mm Square Tube
F1	*	Kador "P" Profile
G1	*	Cross Clamps for 20mm x 49mm Tube
G2	*	Crossover-Clamp For 20mm x 49mm Tube
H1	*	Control Tube (49mm single flute tube)
H2	*	Control Tube (49mm double flute tube)
H3	*	Control Tube Warning Label (<i>not shown</i>)
H4	*	CT3 Inner Control Net
H5	*	CT3 Lower Windbar
H6	*	CT3 Lower Windbar Joiner
H7	*	CT3 Tension Strap
H8	*	CT3 Tension Ratchet Assembly
I1	*	48x100mm Reinforcement Collar
J1	*	Rubber Protection for 5mm Flute
K1	*	50mm Double Return Pulley
L1	*	Anti-Twist Cable Joiner
L2	1	6mm/4mm Cable Joiner and Cover
M1	*	Drive Cable (6mm galvanised wire rope)
M2	*	Main Draw Cable (4mm stainless steel wire rope)
N1	*	Lifting Cable (3mm stainless steel wire rope)
O1	*	49mm Lifting Clamp
P1	* x 6.1m	Top and Bottom Rolling Tube (49mm single flute tube)
P2	* x 6.1m	Middle Rolling Tube (49mm double flute tube)
Q1	*	750 x 48mm Aluminium Tube Joiner
R1	2	Curtain
S1	1	750mm Aluminium 48mm Tube Weight
T1	*	49x30mm Tube End Cap
U1	2	Inner End Cover (drive end and free end)
U2 & U3	7m	Windseal Profile (female & male) (CT2)
V1	2	Outer End Covers (drive end and free end)
W1	6	End Cover Brace T Joiner
X1	*	Free End Trolley Box
AA1	2	Blue Flute Guide Insert (<i>not shown</i>)
AA2	2	Red Flute Guide Insert (<i>not shown</i>)
AB1	1	Supplier CE Approval Guidelines and Label

* Quantity according to the size and style of the system

The system length, number of bays and the control tube option ordered dictates the quantities not stated. Please check the delivery paperwork for precise numbers and control tube configuration.

Product Description

The VVS® is a side curtain ventilation system designed to provide optimum ventilation control for multiple in-line bays. The system is not intended for building human access requirements. The main aspects of the system are the curtain (R1), the end covers (U1 and V1), multiple control tubes (H1) along the length of the system and the drive system, all shown in Figure 1.

ENG

Key Instructions



CAUTION: Potentially hazardous situation: must be avoided otherwise injuries may result.



ATTENTION: Observe the given instructions otherwise the product or adjacent items may be damaged

NOTE: Helpful comments and information to assist in installation or use of your product

NOTE: Colour versions of the user instructions can be downloaded from our website:
www.galebreaker.com

2. Product Details

2.1 Product Model Number

	CT1	CT2	CT3
Bottom Rolling	VV-BR/MK4/1311		
Middle Rolling	VV-MR/MK2/1111		

2.2 Product Serial Number

<Sales_Order_No> / VVE <Length> x <Height>

3. Operating Instructions

3.1 Manual Control

3.1.1 Manual Drive

To open VVS® curtain, the manual gearbox is rotated (using the handle or chain drive) in the direction that causes the curtain top tube to lower. As the top tube lowers and the curtain gets wrapped onto the rolling curtain tube creating a ventilation gap in the building.

To close the VVS® curtain, rotate the manual gearbox in the opposite direction (using the handle or chain drive). The curtain top tube will rise and the curtain and will un-roll from the rolling curtain tube. The ventilation gap in to the building will gradually reduce.



ATTENTION: Care must be taken when moving the curtain to the fully open or fully closed position. With a manual drive gearbox it is possible to move the curtain beyond its end limits which will result in the curtain or drive cable being permanently damaged.

3.1.2 Motor Drive

To operate the VVS® curtain, the motor will be driven by a controller positioned in line of site of the system. Before moving the curtain it is the operator's responsibility to check that there is no one in the vicinity of the moving components of the curtain.

The motor will either be controlled by a dead man (hold-to-run) type switch or the controller will drive the motor in a pulse-pause manner. The curtain will be open and closed by driving the motor in the appropriate direction shown on the controller.

The motor will have been installed with end limits set that automatically stop the curtain in the fully open or closed position. Continuing to instruct the motor to move beyond these positions will not result in movement of the motor.



CAUTION: Before moving the curtain ensure there is no person(s) in close proximity of curtain (inside or outside) that could be harmed by the movement.

3.2 VentLogic V40 - Automatic Control Settings *(if applicable)*

NOTE: The following are to be used in conjunction with the Operating Instructions supplied with the control box. The V40 can operate up to 4 individual systems and each system will require its own settings to be inputted

ENG

3.2.1 V40 Standard Temperature Settings (for each system installed)

Menu Ref.	Function	Unit	Suggested Input
ACTV_	Activation Temperature	°C	Customer Preference
TOLR_	Temperature Tolerance	°C	Customer Preference
MNLT_	Restricting Min. Opening	%	Seasonal Variation
MXLT_	Restricting Max. Opening	%	Seasonal Variation

3.2.2 V40 Optional Settings: Windspeed, Wind Direction, Rain,

NOTE: Before the V40 can be fully operational it must be calibrated for the system run time (a function of ventilation height B).

Menu Ref.	Function	Unit	Suggested Input
PWS	Storm Protection (initial)	m/s	refer to 8.2.1
CWS	Storm Protection (fully closed)	m/s	refer to 8.2.1
MNWD_	Min Wind Direction	°	Dependent on system orientation
MXWD_	Max Wind Direction	°	

Wind Sensor Settings

NOTE: A system will only be controlled by the windspeed if the wind is within the wind direction range for the system. If a wind direction sensor is not installed, all systems will respond to wind from any direction.

The wind sensor parameters are controlled by two inputted values, located in the Back Service Menu (PWS and CWS).

PWS is the windspeed where the system begins to close, and CWS is the windspeed where the curtain will be fully closed. If the measured windspeed is between the initial and fully closed speeds, the curtain will close proportionally.

For example if PWS was set to 2m/s and CWS was 6m/s, then at a wind speed (WS):

WS = 2m/s, then the curtain will remain open

WS = 4m/s, then the curtain will close by 50%

WS = 5m/s, then the curtain will close by 75%

WS = 6m/s, then the curtain will be fully closed

ENG

Due to the very large curtains (longer than 50m) experiencing excessive wind loads, Galebreaker request that the system must always be fully closed at wind speeds greater than 6m/s. Failure to do this may result in the system being damaged.

	ATTENTION: For curtains longer than 50m (BR) / 30m (MR),
	CWS = 6m/s
	For curtains less than 50m (BR) / 30m (MR),
	CWS = 8m/s

3.2.3 Rain

The rain sensor will fully close the system when it detects rain and, if a wind direction is installed, if the wind is within the wind operating range for the system. The rain sensor sensitivity to moisture can be adjusted through the potentiometer located inside the sensor enclosure.

4. Maintenance of Your System

4.1 Uneven Rolling of Curtain – Cleaning Required

Over time, the rolling tube may begin to roll unevenly along the length of the installation. This may be caused by dust and debris collecting on the fabric and in the rolling element of the curtain.

ENG

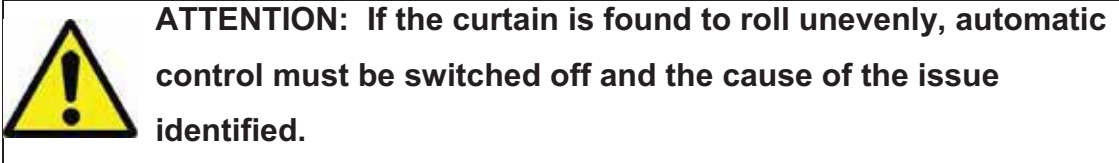

To clean rolling tube:

- 1) Fully close the system using manual controls
- 2) With the system fully closed, isolate power from system and lock isolator switch so that power remains isolated throughout cleaning procedure.
- 3) Using a soft brush, remove any debris that is attached to the curtain material, both inside and outside surfaces, and then any debris that has collected around the rolling tube. It is essential that the curtain and curtain tubes are completely clean.
- 4) Ensure that no one is still cleaning the curtain. Unlock isolating switch, and restore power supply to the system.
- 5) Fully open the system using the manual controls and check that the curtain now rolls evenly. If the issue is rectified the controls can be then returned to automatic control (if available).

4.2 Preventative Maintenance

- Check the wires for fray and damage - replace, tighten and adjust as appropriate. Spare parts are available from your Galebreaker dealer, importer or head office.
- If the curtain material is damaged, repair with special repair kit (code SPS-99) available from your Galebreaker dealer, importer or head office.
- Keep the installation instructions supplied for reference purposes.

4.3 Annual Service



ATTENTION: The VVS® will require a full service by a Galebreaker Approved installer periodically. For manual and motorized (simple switch) this is every 3-years. For automatically controlled systems this must be every 2-years.

ENG

- The drive cable (M1) is a wearing part and has been designed to be replaced during the periodic service.
- Check annually for corrosion of the supporting bolts fixing the product to the building, the bolt holding the shaft into the rolling tube. Replace suspect items to ensure it is safe for operators and bystanders alike.

RAIN INGRESS: Please note that in extreme weather conditions some moisture will penetrate a mesh material.

NOTE: The product has been *tried and tested in the harshest weather conditions, a summary of our guarantee is as follows, see our website for full details:*

- ***Mechanical components: 100% guarantee for two years, followed by an eight year graduated guarantee.***
- ***Electrical components: 100% guarantee for two years, followed by a three year graduated guarantee.***
- ***Wearing parts such as wire rope and pulleys are 100% guarantee for one year.***

5. Health and Safety

5.1 Risks and Protective Measures

 **CAUTION:** The VVS® has many rotating parts and even with the slow operating speed, the end user must be aware of the risk of entrapment of body parts and or clothing along the full length of the system.

 **CAUTION:** Switches controlling the curtain **MUST** be positioned in such a way that when in use the operator has full view of the curtain. If multiple controllers for different systems are located in close proximity, each controller must be clearly marked identifying which system it operates.

 **CAUTION:** Under no circumstances is the system to remain in operation if any of the End Covers (U1 and V1), Cable Drum Cover (B3) and telescopic shaft Gaiters are **NOT** installed.

 **CAUTION:** If the End Covers (U1 and V1) are found to be damaged, isolate power to the system and lock isolator switch. The covers are to be repaired or replaced before power is restored to the system.

 **CAUTION:** Before any maintenance is carried out on the system, isolate power to the system and lock isolator switch.

 **CAUTION:** **NO** settings in the ‘service menu’ of the automatic controller are to be made by un-authorized installers, since this may affect the safety of the system.

 **CAUTION:** At no time should any one climb on the system when stationary or when it is in motion

ENG

5.2 VVS® Noise Levels

A-weighted sound pressure level (dB)	60 dB
C-weighted peak sound pressure level (dB)	70 dB



Manufacturer: Galebreaker Agri Ltd
Galebreaker House
New Mills Industrial Estate
Ledbury
Herefordshire, UK
HR8 2SS

Tel: +44 (0) 1531 637 900
Fax: +44 (0) 1531 637 901

www.galebreaker.com

Designed and Manufactured in the UK by Galebreaker Agri Ltd.
Original Instructions

© Copyright Galebreaker Agri Ltd 2013. All Rights reserved.

Model Number VV-User/MK4/1311

Instruction Ver: 2013/11/ENG